

# PCA2 - On-Load Protection Condition Analyser



- Quick, simple ON-LOAD or OFF-LOAD injection & trip testing
- Tests Relay, Breaker and Battery simultaneously
- Captures critical 'first trip'
- 25A high power intelligent current source
- Injects a precise current into relay independently of the actual load current
- Records entire protection operation sequence: relay, breaker trip and reclose
- Built-in printer for on-site hardcopy
- PC data transfer via supplied USB flash drive

## Overview

Developed in conjunction with EDF Energy UK, the PCA2 is a complete substation protection performance evaluation and recording system. It tests several elements of the protection system (Relay, Breaker & Battery) simultaneously. Its advanced software-controlled current source can inject a precise current into the relay even whilst the system is ON-LOAD. The critical 'first-trip' of both relay and breaker can then be captured and analysed.

It is well known that some relays and breakers can become sluggish after a long period of inactivity. The ideal way to test any protection system is to simulate the precise conditions that occur during a fault whilst simultaneously recording its performance. Performing such a test on a system that has not operated for a long time then yields very useful data as to how the system would perform given a real fault.

Traditionally the different protection parts (relay, breaker & battery) have been tested individually with the circuit first being taken off-line manually. Modern maintenance strategies call for quick non-intrusive methods that can exercise and provide a secure digital record of the performance of the entire protection system with minimal outage times.

As well as operate times, the battery voltage and trip-coil current profile can also be recorded providing data on vital aspects of breaker and overall protection system condition. The PCA2 is a key tool that enables a truly cost-effective Reliability Centred Maintenance Program (RCM) for substation protection.

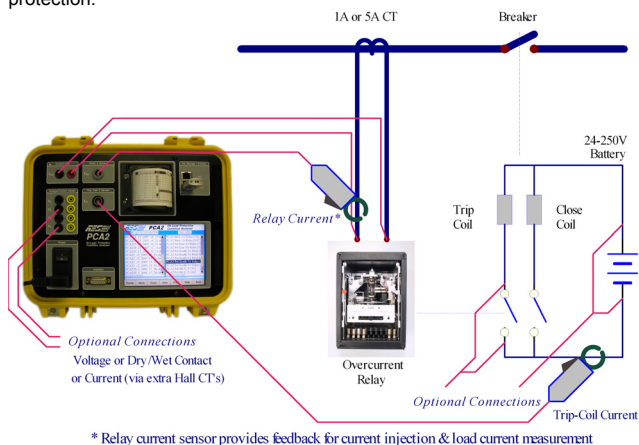

Basic & Optional Connections for ON-LOAD testing

## System Concept

The PCA2 incorporates an advanced current injection unit together with a deep-memory high-resolution multichannel current/voltage/contact-event recorder. Both injection and recording functions can be used together or totally independently.

All instrument control is via a bright high-resolution colour touch-screen. The built-in printer provides an instant hard-copy printout. The supplied USB drive enables convenient and quick data transfer to a PC.

## On-Load Current Injection

The advanced current output of the PCA2 can function in one of two modes: as a general purpose precision injection unit for off-line relay testing or as a special ON-LOAD injection unit. When used for on-load injection, an external clip-on hall-effect CT is used, to record the load current & trip time, and as a feedback element so that a precise and stable current can be injected into the relay, cancelling out the load current.

## Current Output

The current output of the PCA2 employs fully digital waveform generation & low-noise switching amplifier technology. The processor generates high precision waveforms to the required amplitude, frequency and phase angle. The output is continuously monitored and tightly regulated, maintaining an accurate, ultra-low distortion waveform independent of the supply input or load. This guarantees clean sinusoidal waveforms are produced, even into difficult to drive saturating magnetic loads (i.e. electromagnetic relays). If the output deviates from its programmed setting for any reason (open circuit, overburden etc.) then the operator is warned via a message on the display.

## Multichannel current/voltage/contact-event recorder

The PCA2 is also a fully fledged deep-memory high-speed/high-resolution oscillographic recorder.

As well as providing instant hard-copy printout of measurements and relay/breaker timing data, the PCA2 can save the recorded oscillographic data to the supplied USB memory stick for transfer to a PC. Two file formats are currently available: XML for direct loading into Word/Excel/Explorer and COMTRADE (IEEE Standard Common Format for Transient Data Exchange for Power Systems).

The standard PCA2 configuration (PCA2A) provides for 2x Current & 4x Voltage/Contact channels. Each voltage/contact input can also be used for current measurement using additional clip-on Hall probes.

### Specifications – Current Output

#### Current Output

Fully software controlled and regulated  
 0-25A Range / 0.001A Resolution  
 ±45V peak Compliance Voltage  
 Duty cycle: 250VA or 10A (continuous), 500VA or 25A for 30sec.  
 <0.5% Error Typ., 1% Max, <0.2% Distortion  
 DC-1kHz / 0.001 Hz Resolution  
 < ± 0.005% Freq Error  
 Injection start sync'ed with zero crossing and data acquisition.  
 During **ON-LOAD** injections, software automatically phase-locks  
 (45-65Hz) and instantly corrects for any load current variation  
 during injection.

#### Protection & Power Management

Processor continually monitors output for accuracy and waveform  
 quality – any deviation from the programmed value is immediately  
 reported to the user. Fault conditions like over-burden/over-  
 power/over-temperature and open-circuit result in tests being  
 aborted and a warning displayed.

### Specifications – Inputs/Data Acquisition

#### Current Inputs

2x dedicated Current inputs (via supplied clip-on 'Hall' sensors)  
 Trip Coil Current Sensing & Relay Current Sensing/Feedback  
 +/-35A pk (25A RMS) Range / 0.001A Resolution  
 +pk, -pk, instantaneous & RMS measurements displayed  
 <0.5% Error Typ., 1% Max (with supplied sensors)  
 Resolution: 16-bits (15+sign)  
 Bandwidth: DC to 4kHz

#### Voltage/Contact Inputs

4x Ultra-flexible **Isolated** inputs  
 Software selectable as Voltage or Wet/Dry Contact sensing  
 +/-10V & +/-300V pk Ranges  
 +pk, -pk, instantaneous & RMS measurements displayed  
 <0.2% Error Typ., 0.4% Max  
 Resolution: 16-bits (15+sign)  
 Bandwidth: DC to 4kHz  
 (Voltage/contact inputs can also be used to measure current via  
 additional **CT-HE2A** clip-on Hall probes)  
 Can be used to measure & record any arbitrary voltage or contact  
 (e.g. battery voltage, relay trip contacts, breaker auxiliary contacts  
 on-line or main breaker contacts during off-line testing)

#### Contact Mode

Software selectable as wet/dry, contact/2.5-300V  
 Records actual contact voltage over time (not just  
 on/off status)

Protected against incorrect wet/dry selection

#### Time Resolution/Sampling Rate

10,000 samples/sec (±0.1msec resolution)

#### Memory

40Mb memory dedicated to waveform/event acquisition  
 (approx 40 seconds for all channels at 10kHz)

#### Trigger Event

Programmable as Voltage/Current level or Contact open/close or  
 injection start  
 Programmable pre-trigger and post-trigger times

### Specifications – Computer/Screen

**Screen** VGA (640x480) TFT LCD 256K colours with touch control  
**Memory** 64Mb RAM, 512Mb Flash  
**Time/Date** Real-time clock with 1 year battery backup  
**Interfaces** 10/100Mbps Ethernet  
 2x USB (for Flash Drive / Ext. Hard Disk / Barcode-reader etc.)  
**USB Memory Stick** (supplied as standard)  
 1Gb High-speed USB2.0 with write protection switch

### Specifications – Miscellaneous

#### Isolation

Current output, Voltage/Contact inputs & contact outputs are all  
**individually isolated** from each other and chassis to 1500V

#### Interface I/O

15way expansion connector for future add-ons/expansion

#### Input Power

95-260VAC input / 45-65Hz AC  
 40W no load, 600W continuous max

#### Physical / Environmental

274x247Wx180m / 9.5kg Weight  
 0-50°C Operating Temperature  
 5-95% Relative humidity (non-condensing)  
 IP65 Protected Enclosure (when closed), airtight, watertight.  
 CE Marked  
 Tested to EN50081-2 (emissions) & EN50082-2 (susceptibility)

### Software

#### Manual Test Mode

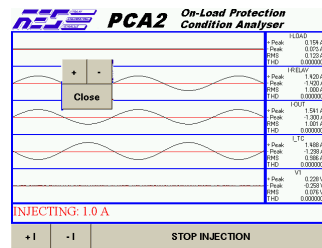

General purpose current source &  
 timer.

Quick On-Load or Off-Load  
 Injections

Overcurrent Relay Testing  
 (Operate times)

Current/Voltage/Contact Status  
 Measurements

#### Auto Test Mode

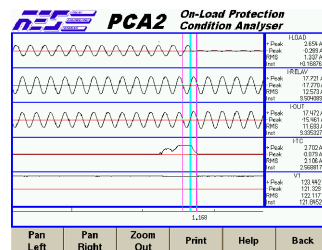

On-Load & Off-Load testing with  
 recoding/saving on all channels

Timing analysis & measurements

Automatic Relay & Breaker timing  
 measurements

Automatic Trip-Coil waveform  
 analysis

#### Utilities

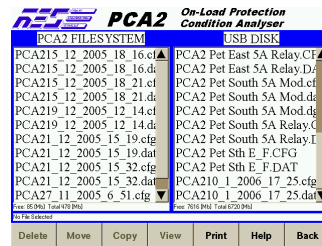

Results Saving/Transfer to USB  
 drive

Software updates via USB drive

Online operating manual

Quick-start testing from saved test,  
 last test or user-defined setups

### The Company

Relay Engineering Services Limited (RES) is a pioneering technology  
 company that develops and markets specialised equipment & software  
 solutions exclusively for the relay testing and power systems protection  
 marketplace.

The company is the UK market leader in automatic protection relay test  
 equipment. RES is an ISO9001 registered company and has a long record as  
 an approved supplier to every main Electricity Generation, Transmission,  
 Distribution and Railway Maintenance Company in the UK as well as to over  
 30 countries worldwide.

All RES products are rugged, field-proven instruments designed to provide  
 superior long-term service and reliability. This is backed up by responsive  
 customer support services with comprehensive pre and post-sales technical  
 backup from a team of highly experienced application engineers.

The company also manufactures dedicated protection relay set sets, battery  
 discharge testers and HV circuit-breaker testers.

### Ordering Information

| code: PCA2A  | code: CT-HE2A   |
|--|---|
| <p>PCA2<br/>                 Protection Condition Analyser,<br/>                 includes:<br/>                 Padded protective case<br/>                 Set of power &amp; touch-proof<br/>                 interconnecting cables &amp;<br/>                 crocodile clips<br/>                 2x <b>CT-HE2A</b> clip-on Hall probes<br/>                 1Gb USB Memory Stick<br/>                 Operating manual<br/>                 Calibration certificate<br/>                 Software for viewing results on<br/>                 PC's (Win 98/XP/2000+)</p> | <p>Additional clip-on Hall-effect CT<br/>                 – enables Voltage/Contact<br/>                 inputs to measure/record<br/>                 currents<br/>                 Specs as for std Current Inputs<br/>                 (extra CT's can also be used to<br/>                 record all 3-ph secondary<br/>                 currents)</p> |

Our policy of continuous product improvement may mean that equipment supplied differs slightly  
 from specifications in this publication – check at time of ordering.