

LINEARLY SPEED / RPM CONTROLLER

CS2-RL(1.4)

FEATURE

- Measuring Frequency **AUTO RANGE 0.001~100KHz / ~140KHz(optional)** / Contact, NPN, PNP, Voltage pulse
- Accuracy: $\pm 0.005\%$; Display range: 0~99999
- **Decimal Point auto moving according to input frequency**
- User function, easily programmed by the front panel
- **4 relay for Hi / Lo / Go / DO energized with Start Delay / Hysteresis / Energized & De-energized Delay / Relay Energized Hold..... functions**
- Analogue output and RS 485 communication port in option
- **3 external control inputs for Relative PV / PV Hold / Maximum or Minimum Hold / DI / Reset for Relay Energized Hold....**
- CE approved



The Newest

www.transducersandmeters.com

ORDER INFORMATION

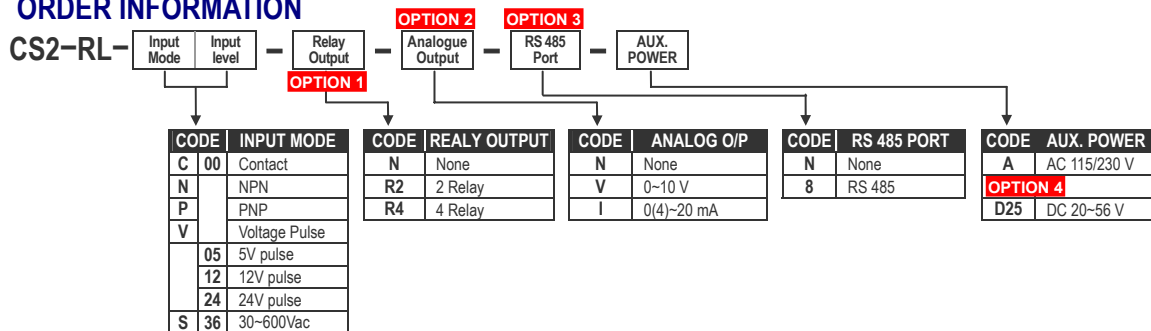

SPECIFICATION

Input Frequency	Input Mode	Input Level
0.001Hz ~ 5 Hz	Contact	
0.001Hz ~ 50 Hz	NPN	High Level: 8~12V; Low Level: 0.0~4.0 V (with excitation supply 12Vdc)
0.001Hz ~ 100KHz	PNP	
0.001Hz ~ 140KHz (optional)	Voltage Pulse	High Level: over 2/3 of input level Low Level: under 1/3 of input level

➤ Input Mode & Level changeable by dip switch of rear terminal block.

- Calibration: Without calibration process.
- Accuracy: $\leq \pm 0.005\%$ of RDG $\pm 1C$;
- Sampling time: 10 cycles/sec ($\geq 10Hz$);
f cycles/sec ($\leq 10Hz$)
- Response time: ≤ 100 msec (when the AvG = "1")
- Operating
- Operation key: 4 keys for Enter(Function) / Shift(Escape) / Up / Down
Up key: increase the number / back to previous function
Down key: decrease the number / go to next function
Shift/Escape key: move the flash digit position / Return back to upper level
Enter/Fun key: enter the parameters you set or function select
- Security function: 4 digits password
- Lock function: 3 function group lock level for None/User Level/ Engineer Level / All(Engineer Level & User Level)

Display & functions

- LED: Measuring value: 0.56" red high-brightness LED
Relay output indication: square red LED
External control input: square green LED
RS 485 communication: square red LED
Max. / Mini. Hold: square red LED
- Low Cut function: Low.cut :Settable range: -5000~5000 counts
- Average function: AvG :Settable range: 1~99 times
- Digital Filter: D.FiLt : Settable range: 0(None)/1~99 times
- Over range indication: ovFL, when input is over 120% of input range Hi
- Reading functions
- Input range: 0.001Hz ~ 100KHz
0.001Hz ~ 140KHz specify in option
- Resolution: Auto / Semi-Auto / Fix; 3 mode selectable
(Auto-Moving for d.p.)
Decimal point will Auto-changed according to input

- Compensation factor: Compensate error from 0.0001~9.9999
- Over range indication: ovFL, when input is over 120% of input range Hi
- Display functions: Present Value / Maximum Hold / Minimum Hold / Write to display by RS485 command

Max. (or Mini.) Hold & Reset

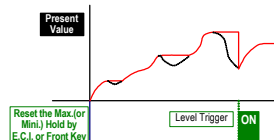

Data Hold & Reset

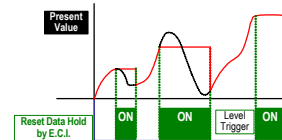

Control functions

- Control relay: 2 Relays SPDT, 5A/230Vac, 10A/115V
2 Relays SPST, 1A/230Vac, 3A/115V
- Relay Output: Energized levels compare with set-points:
Hi / Lo / Hi.HLd / Lo.HLd / do / Go-1.2 / Go-2.3
DO function: Energized by RS485 command
Relay Energized Hold : Selectable Low or High Hold

Hi / Lo / Go Relay Energized

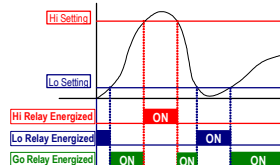

Hi(Lo) Energized Hold & Reset

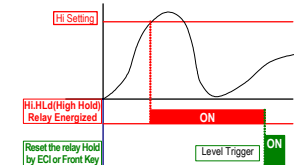

- Functions: Start delay / Energized & De-energized delay / Hysteresis
Start band: 0~9999 counts
Start delay time: 0:00.0~9(Minutes):59.9(Second)
Energized delay time: 9(Minutes):59.9(Second)
De-energized delay time: 9(Minutes):59.9(Second)
Hysteresis: 0~5000 counts

Start Delay

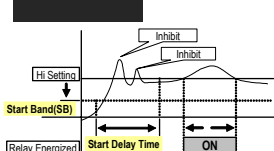

Energized / De-energized Delay & Hysteresis

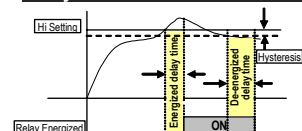

C2-11

LINEARLY SPEED / RPM CONTROLLER

CS2-RL(1.4)

External Control Inputs(ECI)

- Input mode: 3 ECI points, Contact or open collect input
- Functions: *Relative PV / PV Hold / Reset Max or Mini. Hold / DI / Reset for Relay Energized Hold*
Debouncing time: 5 ~255 x 8mseconds

Analogue output(option)

- Accuracy: $\pm 0.1\%$ of F.S.; 16 bits AD converter
- Ripple: $\pm 0.1\%$ of F.S.
- Response time: ≤ 200 msec. (10~90% of input)
- Isolation: AC 2.0 KV between input and output
- Output range: Specify Voltage or Current
Voltage: 0~5V / 0~10V / 1~5V selectable
Current: 0~10mA / 0~20mA / 4~20mA selectable

- Output Capability: **Voltage: 0~10V: $\geq 1000\Omega$;**
Current: 0(4)~20mA: $\leq 600\Omega$
- Functions: **Ao.Hi(output high): PV Hi vs. output range Hi**
Ao.Lo(output range Low): PV Low vs. output range
Ao.LMt(output High Limit):
0.00~110.00% of output High

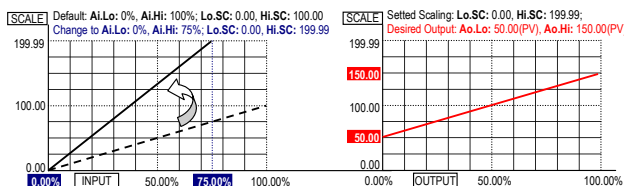

RS 485 communication(optional)

- Protocol: Modbus RTU mode
- Baud rate: Selectable 2400/4800/9600/19200/38400
- Data bits: Selectable 7 or 8 bit
- Parity: Selectable Even, odd or none (with 1 or 2 stop bit)
- Device no: Setable 1 ~ 255
- Write function: Write to display value from PC's RS485 command

Power

- Excitation Supply: DC 12V, 30mA
- Power Supply: AC 115/230V $\pm 10\%$, 50/60Hz
Optional DC 20~56V
- Power consumption: 5.0VA
- Back up memory: By EEPROM

Environmental

- Operating temperature: 0~60 °C
- Operating relative humi.: 20~95 %RH, Non-condensing
- Temperature coefficient: ≤ 100 PPM/°C
- Storage temperature: -10~70 °C
- Enclosure: Front panel: IEC 549 (IP54)

Electrical safety

- Dielectric Strength: AC 2.0 KV for 1 min
Between Power / Input / Output / Case
- Insulation resistance: $\geq 100M$ ohm at 500Vdc
- Isolation: Between Power / Input / Output
- EMC: EN61326
- Safety: EN61010

Mechanical

- Dimensions: 96mm(W) x 48mm(H) x 120mm(D)
- Panel cutout: 92mm(W) x 44mm(H)
- Case Materiel: ABS fire-protection (UL 94V-0)
- Mounting: Panel flush mounting
- Terminal block: Plastic NYLON 66 (UL 94V-0)
10A/300Vac, M2.6, 16~22AWG
- Weight: 550g

FRONT PANEL

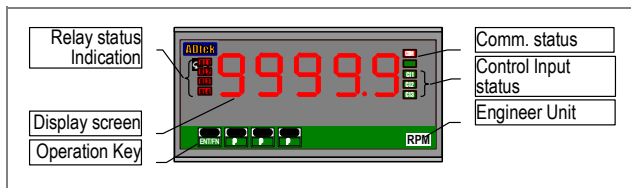

DIMENSIONS

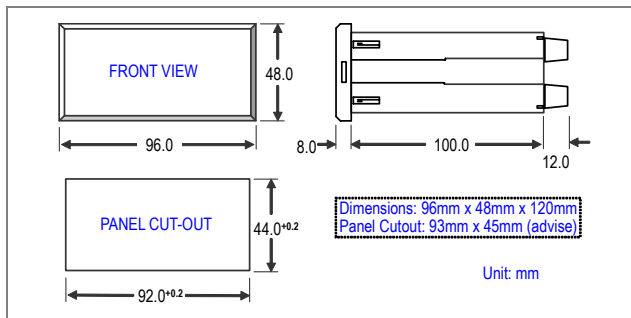

INSTALLATION

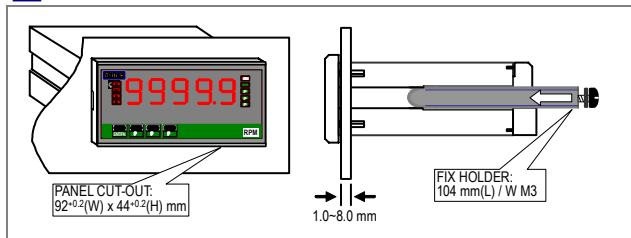

CONNECTION DIAGRAM

