

**PMAC720 Multi-Function Power Meter**  
**Installation & Technical Data Sheet**  
**PTSTech - Pilot V7.0**

**Power True Systems Corp.**

P.O. Box 270757 Tampa FL 33688 USA

Phone: 813-969-2951

Fax: 813-961-8303

Website: [www.transducersandmeters.com](http://www.transducersandmeters.com)

## 1. General information

The PMAC720 is a high accuracy and reliable digit 3-phase power meter designed for use in industrial, commercial, and utility power distribution switchboards and substations. The PMAC720 answers the ever-increasing concern for 'clean', reliable power by integrating the many critical aspects of power monitoring, analysis, and control into one simple and economical meter. It is a state of the art alternative to traditional analog electromechanical metering devices, replacing numerous individual transducers and meters, and offering many features previously unavailable in power meter.

Functions offered:

Real Time measurements

Energy metering

Calculation of the harmonic distortion rate

SOE(Event Log)

Setpoints

TOU ( Time of Use )

MODBUS communication

Optional module(I/O)

Analog inputs/outputs

Note: The functions marked with need the extra support of hardware circuit and relevant software.

The functions marked with supply one MODBUS communication and extend second MODBUS communication by using hardware.

### 1.1 Measurements

The PMAC720 offers varies of high accuracy real-time, 3-phase measured parameters and status parameters. All parameters are quickly accessible via the front panel display or through the meter's communication port. Measurements include: Volts, Amps, Neutral/Ground Current, kW, kvar, Power Factor, Frequency, Energy, and Harmonic etc.

Following are the measurements offered:

Parameters		Display	Communication
<b>Voltage</b>	Phase/neutral voltage, phase/ phase voltage	Primary	Secondary
<b>Current</b>	3 phases, neutral	Primary	Secondary
<b>Active power</b>	3 phases, total	Primary	Secondary
<b>Reactive power</b>	3 phases, total	Primary	Secondary
<b>Apparent power</b>	3 phases, total	Primary	Secondary
<b>Power factor</b>	3 phases, total	Primary	Primary
<b>Frequency</b>		Primary	Primary
<b>Energy</b>			
Active energy	Import, export	Primary	Primary
Reactive energy	Inductive, capacitive	Primary	Primary
<b>Harmonic</b>			
Voltage	1th~31st odd	Percent	Percent
Current	1th~31st odd	Percent	Percent
<b>Analog inputs**</b>	4~20mA	Primary	Primary

Note: 1.The functions marked with " \*\* " need the extra support of software.

## 1.2 Optional module

The PMAC720 can be installed at its end with optional module at any moment. The optional module can offer configurable status inputs(DI) and relay outputs(DO).

Optional module has five types.

Module's name	Functions	Display	Communication
A	4 Status Inputs (Dry contact) 4 Relay Output Ports	The status of DI and DO can be got through the display panel	The status of DI and DO can be got and the parameters of relay can be set through communication.
B	8 Status Inputs (Dry contact) 2 Relay Output Ports		
C	4 Status Inputs (External Voltage Required) 4 Relay Output Ports		
D	8 Status Inputs (External Voltage Required) 2 Relay Output Ports		
E	2 Pulse Outputs 2 Analog Outputs	Null	Null

\* If users select the function of setpoints, relay's control mode and trigger condition can be set through communication. See later chapter for the details.

Software of the PMAC720 can be upgraded through communication, thus user's version can keep consistent with newest version provided by PTS-Tech PILOT. Users can ask us for newest version or we will inform users.

## 1.3 Panel

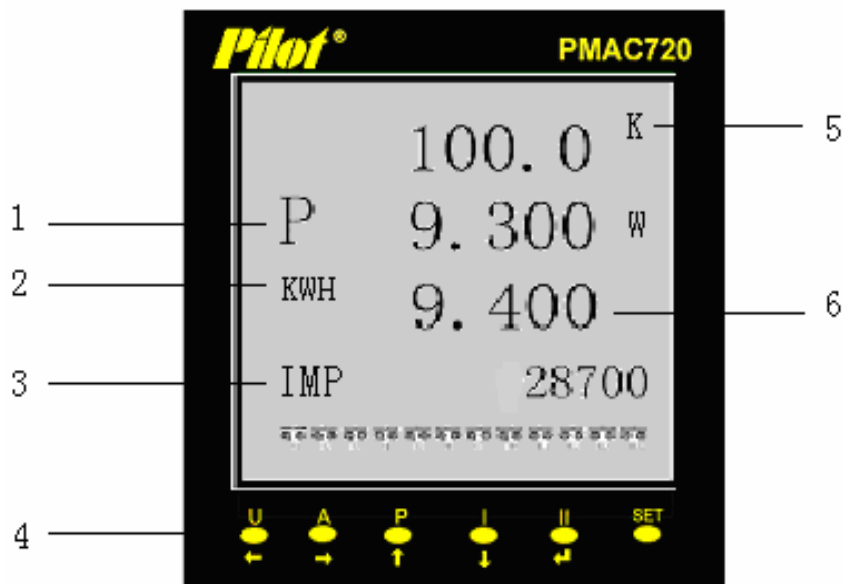

- 1: Prompt for data displayed
- 2: Unit of energy
- 3: Prompt for data displayed
- 4: Dual-function keys
- 5: Units
- 6: Data

## 1.4 Control and Events

The PMAC720 can provide optional functions like internal clock, setpoints, SOE and TOU.

Users can set the parameters of relay through communication. Users can program own communication software with open MODBUS protocol, and also can use communication software provided by us to set parameters.

The PMAC720 with full configuration provides accurate clock, and can record a wide variety of event types, such as status input activity, relay output activity and setpoints conditions. The events are date and time stamped in order to make it convenient for user's analysis.

See later chapter for details.

## 2. Installation and Connection

### 2.1 Environment

#### 2.1.1 Environmental request

- \* Operating-temperature range: -20 C ~ +70C
- \* Storage-temperature range: -40 C ~ +85C
- \* Humidity: 5% ~ 95%RH, Non-condensing

#### 2.1.2 Installation

The PMAC720 is fixed in wall with two slide fixtures.

The cut in the wall should strictly comply with the size marked in the following picture.

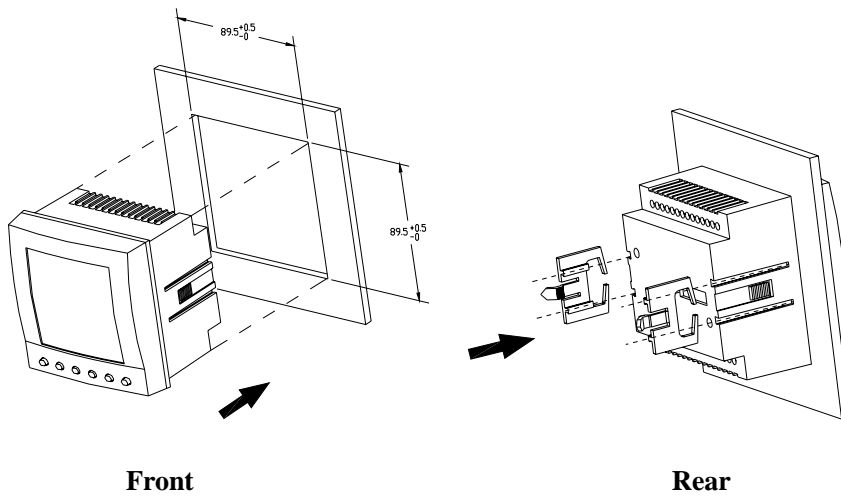

#### 2.1.3 Structure and Terminals

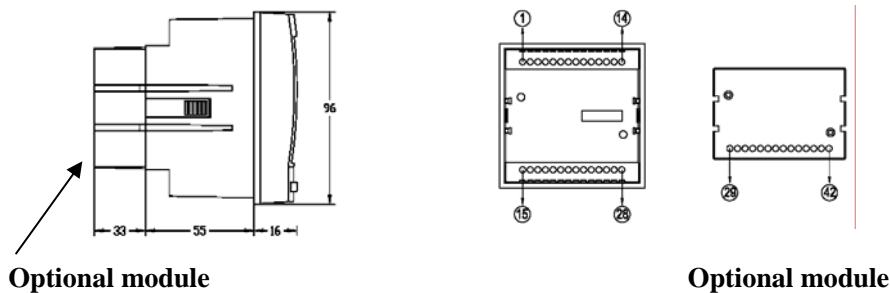

## 2.2 Power supply

Operating range: 85Vac~265Vac, 80Vdc~300Vdc

## 2.3 Connection

The PMAC720 supports various connection modes. Illustrate as follows:

Voltage less than 300V(phase to neutral)/520V(phase to phase), 3-phase 4-line systems (No PT and 3 CTs)

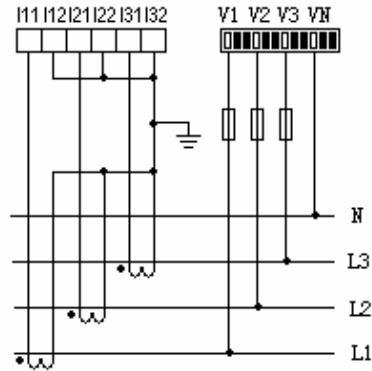

Voltage higher than 300V(phase to neutral)/520V(phase to phase), 3-phase 4-line systems (3 PTs and 3 CTs)

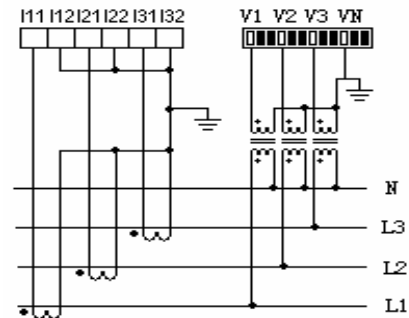

Voltage less than 300V(phase to neutral)/520V(phase to phase), 3-phase 3-line systems (No PT and 3 CTs)

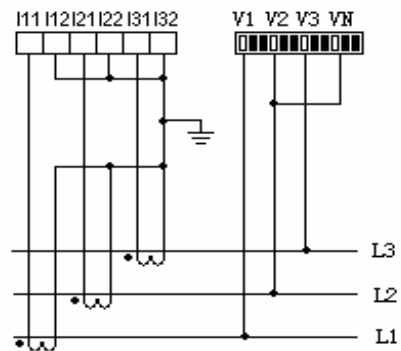

Voltage less than 300V(phase to neutral)/520V(phase to phase), 3-phase 3-line systems (No PT and 2 CTs)

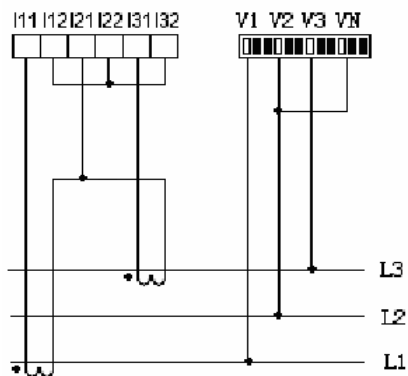

Voltage higher than 300V(phase to neutral)/520V(phase to phase), 3-phase 3-line systems (2 PTs and 3 CTs)

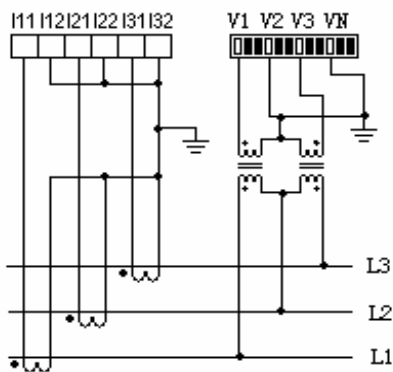

Voltage higher than 300V(phase to neutral)/520V(phase to phase), 3-phase 3-line systems (2 PTs and 2 CTs)

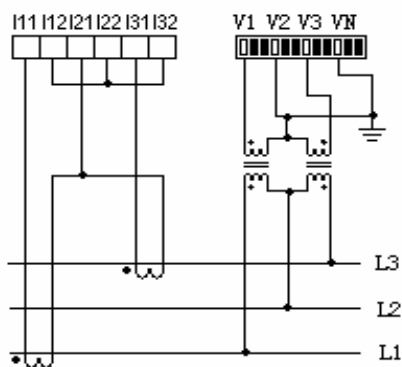

## 2.4 Communication

The PMAC720 can provide two RS485 communication ports. For most use scenes one port is enough.

To connect refers to the diagram. In order to avoid signal reflecting, usually a 120 ohm resistance will be shunt by the end of net.

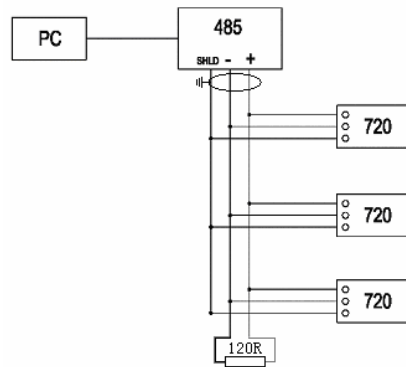

## 2.5 Status inputs

The PMAC720 provides flexible configurable 4~8 status inputs. They can be used to monitor breaker's position signal, knife switch's position signal etc.

The power supply for contact is alternative. It can be supplied internally with 30VDC, and external contacts don't give voltage signal. Or external high voltage is given. According to different voltage status of external contacts, two connection methods are possible, as follows:

### External dry contact

If external status signal is only a position signal, the PMAC720 must internally output feedback voltage signal when contacts are closed, usually connection method as shown in following figure is applied.

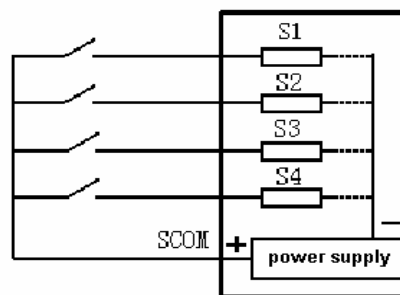

Reference connection diagram of dry contact inputs

### External active contact

When external status signal provides not only position information, but also feedback voltage signal, the PMAC720 cannot apply internal power output, and must adjust its internal configuration, and accordingly modify the wire connection. The wiring connection is shown as follow:

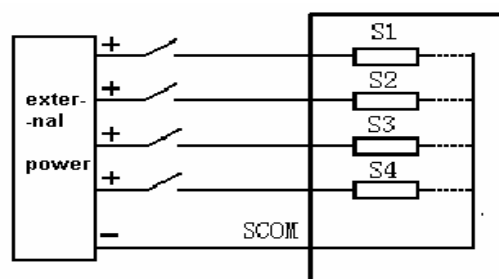

Reference connection diagram of external active contact inputs

Generally when external contact closes, the relevant display icon on display panel of the PMAC720 will be closed, and meanwhile internal status information is set to 1. When external contact breaks, the relevant display icon on display panel of the PMAC720 will open, and internal status information is set to 0.

If active contacts are applied on the field, users should inform us of voltage class of external power supply when they place orders, so that we can provide suitable hardware configuration. Otherwise, equipment damage will be caused.

## 2.6 Relay outputs

The PMAC720 provides 2~4 relays output ports. The capacity of relay is 250VAC/5A, 30VDC/5A. If any other type with different capacity is needed, please inform us when you order.

Please see The PMAC720 MODBUS Protocol for the details about how to set the corresponding parameters of the relays.

## 2.7 Pulse outputs

PMAC720 optional module can support maximum two pulse outputs ports for the use of energy measurement. The first one is correspond to the pulse outputs of total active energy, second is correspond to the pulse outputs of total reactive energy. The default pulse constant is 1: that is 0.1 degree export 1 pulse (example of pulse constant: when pulse constant is 10, 1 degree export 1 pulse. When the pulse constant is 100, 10 degrees export 1 pulse. Pulse constant can be set through communication and the setting range is 1~65535. Following is the connection picture for your reference:

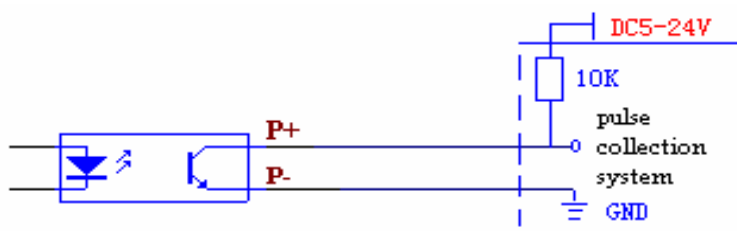

## 2.8 Analog outputs

PMAC720 support two types of analog outputs, one is via one analog output port of basic module and the other is via special optional module to export two analog outputs. The maximum export load is 500 ohm.

Analog output port can be defined with voltage, current and power etc. Connection picture as following:

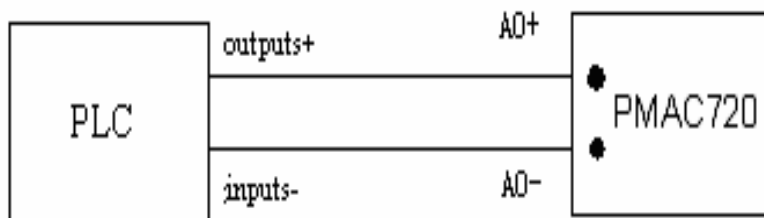

## 2.9 Analog inputs

In some occasions, for example data monitor of main transformer, it needs to measure the temperature and pressure. PMAC720 basic module can provide one analog input port to achieve this function. (Notice: once selected analog input function, it can't support one analog output function anymore).

### 3. Measurement

#### 3.1 Voltage

Whether or not potential transformers (PTs) are required depends on the nature of the system being monitored and the voltage levels to be monitored.

When the system voltage level is below 300V (phase/neutral)/520V (phase/phase), the voltage measurement circuit of the PMAC720 can directly connect with the system.

When the system voltage level is above 300V (phase/neutral)/520V (phase/phase), the voltage measurement circuit of the PMAC720 must be connected with the system via PTs. Usually, users can select the PTs with secondary rated output of 100V. Use of PTs will have direct affection on measurement accuracy of the meter, so users should consider the linearity and accuracy level of PTs when they select the PTs.

Overload capacity of the PMAC720 for voltage measurement is generally 1.3 times the rated measuring voltage. Users should pay attention to that when they design, in order to prevent saturation of internal measurement circuit and cause inaccurate measurement.

#### 3.2 Current

Usually, the PMAC720 must be used to measure the current using CTs. Secondary rated output of CTs must comply with rated current input of the PMAC720. After CTs are used in the system, it is strictly prohibited that related circuit is open circuit, or otherwise primary excitation will generate high voltage at secondary circuit, causing personal injury or death and equipment damage.

When users install or maintain CTs, they must take necessary protection measures (e.g. make CTs short circuit).

Overload capacity of the PMAC720 is 1.4 times rated measuring current. Users should pay attention to that when they design, in order to prevent saturation of internal measurement circuit and cause inaccurate measurement.

#### 3.3 Active power

The PMAC720 can calculate active power of three phases and total by measuring voltage and current signals.

#### 3.4 Reactive power

The PMAC720 can calculate reactive power of three phases and total.

Active power and inactive power have symbols. Users should pay attention to it.

Note
During connecting wires, users should pay attention to the phase sequence corresponding relation between voltage and current, or otherwise wrong power data will be obtained. Besides, users should pay attention to terminal connection of CT (terminals with same names should be connected), or otherwise negative power data will be obtained.

#### 3.5 Power Factor

The PMAC720 can calculate power factor of three phases and total. Measurement range is from  $-1.000 \sim +1.000$ . Corresponding wire-connection and connection of terminals of CT with the same names will affect actual calculated value of power factor.

#### 3.6 Frequency

When the PMAC720 operates in different modes, measured frequency data is acquired through different channels. In mode, the PMAC720 measures frequency through phase C voltage channel. In 4Y modes, the PMAC720 measures frequency through phase A voltage channel. If phase A lacks, through phase B. If phase A and B lack, through C.

### 3.7 Analog measurement

Analog input measurement is an optional function of the PMAC720. It can measure current of 4~20mA or voltage. Input can be connected with converter and sensor. And it can be used as measurement port for temperature and pressure etc.

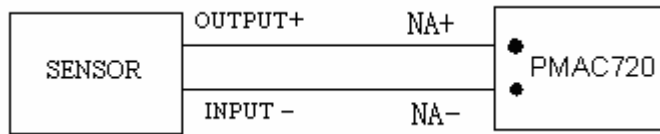

## 4. Harmonic

### 4.1 General

The PMAC720 can provide up to 31st harmonic analysis in order to make user analyze harmonic distortion conveniently.

### 4.2 Voltage harmonic

The PMAC720 can measure up to 31st harmonic distortion rate of voltage.

Harmonic data is expressed with percent of base wave. For example, '11' is displayed on display panel; it means that actual value is 11% of base wave.

HD01	100	
U	100	%
	100	

Note	
Users can look over harmonic data through display or communication.	

### 4.3 Current harmonic

Harmonic data of current is expressed with percent of base wave. For example, '11' is displayed on display panel; it means that actual value is 11% of base wave.

HD01	100	
I	100	%
	100	

## 5. Energy and TOU

### 5.1 General

The PMAC720 can calculate energy parameter. According to power flow, it can provide imported, exported and net value of energy.

Energy parameters are accumulating values. Maximum range of energy readings is 999,999,999KWh or Kvarh. Beyond this value, readings roll over to zero (0).

Users can also clear it compulsively.

Note	
Users can clear energy through display panel or communication.	

## 5.2 Active energy

By accumulating active power, active energy can be obtained.

## 5.3 Reactive energy

By accumulating reactive power, reactive energy can be obtained.

## 5.4 Time of use system

Time of Use (TOU) is a billing scheme that uses a varying tariff structure that depends on the time of day. In general, power is more expensive during peak periods than in non-peak periods to encourage customers to transfer usage to off hours. The TOU feature in the PMAC720 can be used to record energy usage for virtually any tariff structure.

The PMAC720 can calculate energy with 8 tariffs at most. I.e. 24 hours in a day can be divided into 8 sections of time; the unit for each section is 0.5 hour. One section has one tariff. The start time of section 1 is 0 clock acquiescently (the start time can be any whole number under 49). The start time of section 2 should be the end time of section 1. Each tariff records independent active energy and reactive energy.

Illustrate as follows:

Example 1:

Sections of time	Start time	Tariffs
1	0	1
2	12	2
3	20	0
4	24	3
5	28	1
6	34	0
7	40	2
8	46	3

The start time of section 1 is clock 0; the end time is clock 6; the tariff is 1. The start time of section 2 is clock 6; the end time is clock 10; and the tariff is 2. The rest may be deduced by analogy. The start time of tariff 8 is clock 23; the end time is clock 24; and the tariff is 3.

If users' start time of TOU isn't 0 clock. Please refer to following operation.

Example 2:

If users divide a day into 5 tariffs, operate as follows:

Sections of time	Start time	Tariffs
1	12	1
2	20	2
3	24	1
4	28	3
5	48	0

The start time of section 1 is clock 6; the end time is clock 10; the tariff is 1. The start time of section 2 is clock 10; the end time is clock 12; and the tariff is 2. The rest may be deduced by analogy. The start time of section 5 is clock 24; the end time is clock 6; and the tariff is 0.

## 6. SOE (Event Log)

### 6.1 General

The PMAC720 records automatically the 100 most recent events. Though SOE, users can analyze faults in power system conveniently. A SOE counter is offered.

## 6.2 Event types

A wide variety of the event types are recorded by this log:

- 1) Setpoints (alarm) status.
- 2) Relay output activity.
- 3) Status input activity

## 6.3 Time

The time when the event happens is recorded as UNIX time in the PMAC720 with 1ms resolution.

## 6.4 Event format

When the event happens, using software of PILOT, users can get the following information:

Event	Time
Relay 1 closes	16:8:25.576 02/08/02

Please see The PMAC720 MODBUS Protocol for the details.

## 7. Setpoints

### 7.1 General

The PMAC720 provides user-programmable setpoints system. It can monitor almost all the parameters in power system. The PMAC720 can be provides 10 setpoints. 6 setpoints are Analog setpoints. The other 4 setpoints are logic setpoints.

### 7.2 Analog setpoints

#### 7.2.1 Monitor types of analog setpoints

Two setpoints types are provided as: HIGH LIMIT, LOW LIMIT. Users can set the limit value according to their requirement.

#### 7.2.2 Trigger parameters of analog setpoints

Analog setpoints can monitor all parameters in power system. They are as following:

	Parameter types		Parameter types
Voltage	Voltage phase A	Current	Current phase A
	Voltage phase B		Current phase B
	Voltage phase C		Current phase C
	Voltage phase/phase AB		Neutral current
	Voltage phase/ phase BC		Current unbalance
	Voltage phase/ phase CA		All three phases current meet condition.
	Phase zero voltage		Any phase current meets condition.
	Voltage unbalance	Others	Frequency
	All three phases voltage meet condition.		
	All three phase / phase voltage meet condition.		
	Any phase voltage meet condition.		
	Any phase/phase voltage meets condition.		

#### 7.2.3 Parameter limit of Analog setpoints (action condition)

After the trigger parameter is selected, the parameter limit needs to be set. For example, voltage phase A is selected as trigger parameter, and the parameter limit is set as 24000. It means that when voltage phase A exceed 240.00V, the action condition of the setpoints is provided. See The PMAC720 MODBUS Protocol for the details.

### 7.3.3 Action conditions of logic setpoints

Please see The PMAC720 MODBUS Protocol for the details.

### 7.3.4 Action delay time of logic setpoints

When the setpoints meet action condition, it will be active after the delay time elapses. In the delay time, if the trigger parameter value returns, the setpoints is inactive. Unit of delay time is one cycle (20ms). The range of the delay time is 0~9999. 0 means if condition is met, the setpoints is active immediately.

### 7.3.5 Action objects of logic setpoints

When any setpoints is activated, the corresponding action object can be set. The object can be any relay or nothing.

### 7.3.6 Example

Users want to make logic judgment to S1, S2 and Analog setpoints SP2. When S1 closes; S2 opens and SP2 is active, relay 2 will act after 50 cycles. Set as follows:

Trigger parameters	Action condition	Judgment type	Delay time	Action object
S1	1	AND	50	Relay 2
S2	0			
SP2	1			

Note: 1 means that status closes or setpoints is active.

0 means that status opens or setpoints is inactive.

When above three parameters are triggered, the relay 2 will act after 50 cycles.

## 8. Display and Operation

### 8.1 General



The PMAC720 has a large LCD and 6 dual -direction keys to switch measurement and programming interface. Most parameters of the PMAC720 can be displayed and programmed via keys on panel.

### 8.2 Key functions

**U:** Switch to voltage, energy, time

**A:** Switch to current, energy, time

**P:** Switch to power, energy, time

**I:** Switch submenu

**II:** Switch menu

**SET:** Switch display and programming mode

Under the display mode, pressing SET will switch to the programming mode. Under the programming mode, pressing SET will switch to the display mode.

#### **8.4.2.1 Address**

The communication address of meter can be set. The PMAC720 supports MODBUS protocol, and the valid range is from 1 to 247.

#### **8.4.2.2 Baudrate**

The PMAC720 can provide two communication ports. The baudrate can be 2400, 4800, 9600 or 19200 bps.

#### **8.4.2.3 PTs rating**

In order to ensure the right voltage measurement of the PMAC720, PTs rating must be set right. The rating value of PTs is equal to rated primary value divided by rated secondary value. If there is no external PTs, the default value is 1. The range is from 1 to 9999.

#### **8.4.2.4 CTs rating**

In order to ensure the right current measurement of the PMAC720, CTs must be set right. The rating value of CTs is equal to rated primary value divided by rated secondary value. The range is from 1 to 9999.

#### **8.4.2.5 Voltage mode**

The voltage mode needs to be set right, and then the value of power etc can be obtained right. the PMAC720 supports two voltage mode, 4Y and 3

Please see chapter 2.3 for some connection modes.

Note
When 3-phase 4-line systems are connected, the mode should be set 4Y.
When 3-phase 3-line systems are connected, the mode should be set 3

#### 8.4.2.6 Clearing energy

When users want to restart to accumulate energy, energy can be cleared through the menu. If users select TOU, energy for TOU will be cleared at the same time.

#### 8.4.2.7 Meter information

Configuration information and version can be inquired in the PMAC720 in order to maintain the meter.

### 9. Communication

The PMAC720 can provide two RS485 communication ports.

#### 9.1 Communication medium

The communication medium is number 22 twisted-pair. At most 32 meters can be connected in one communication net. If there is no repeater, the communication bus shouldn't exceed the length of 1,200m.

#### 9.2 Communication protocol

The PMAC720 supports MODBUS protocol. Please see The PMAC720 MODBUS Protocol for details.

#### 9.3 Communication parameters

If the parameters isn't set right, the meter won't be able to communicate.

The parameters includes:

- \* Address: Every meter has exclusive address. Users can change it.
- \* Baudrate 1: 2400, 4800, 9600, 19200
- \* Baudrate 2: 2400, 4800, 9600, 19200

### 10. Maintaining and Removing faults

Possible questions	Possible reasons	Possible measures
No display	Wrong The power supply isn't given right.	Check if the power supply is connected to L/+ and N/-.
The measurement value of voltage is wrong.		Check if the neutral point is connected to ground. Check if the input voltage matches rated value. Check if the rating value of PTs is right.
The measurement value of current is wrong.		Check if the input current matches rated value. Check if the rating value of CTs is right.
The measurement value of power is wrong.		Check if the voltage mode is set right. Check if the corresponding relation of phase sequence between voltage and current is right. Check if the terminal connection of CTs is right.
The status input is wrong.	The voltage for status is wrong.	Check if the connection is right. Check the type of external contact matches the meter.

The relays don't act.	No action order is obtained.	Check the communication lines.
	The control mode is wrong.	Check if the control mode of relay is right.
Communication doesn't success.	The address is wrong.	Check if the address is set right. Ensure that meter has its exclusive address.
	The baudrate is wrong.	Check the baudrate.
	Resistance 120 isn't connected.	Check the resistance.
	The communication cables are interfered.	Check if the shield layer is connected to ground at one point right.
	The communication cables have broken.	Check if the communication cables have broken.

## 11. Technical datasheet

<b>Size</b>	Panel: 96mm(L) x96mm(W) x16mm(H)	
	Main unit: 89.5mm(L) x 89.5mm(W) x55mm(H)	
	Optional module: 89.5mm(L) x 62mm(W) x 33mm(H)	
<b>IP degree</b>	Panel	IP54
	Sides and back	IP20
<b>Measurement</b>	4Y	
	3	
<b>Power supply</b>	See chapter 2.2	

Parameters	Ranges		Precision
<b>Voltage</b>	Direct	300V(phase/neutral)/ 520V(phase/phase)	0.2%
	Via PT	Primary: 0~999,999V	
		Secondary: 57.7/100V	
<b>Current</b>	Primary: 0~49,999A		0.2%
	Secondary: 1A or 5A		
<b>Power</b>	Per phase: 0~100MW/ Mvar		0.5%
	Total: 0~300 MW/ Mvar		
<b>Energy</b>	0~99,999,999.9KWh/Kvarh		
<b>Frequency</b>	45~65HZ		0.01HZ
<b>Power factor</b>	-1.000~+1.000		0.5%

EMC	
<b>Electrostatic discharge immunity test</b>	IEC61000-4-2 Level 3
<b>Radiated immunity test</b>	IEC61000-4-3 Level 3
<b>Electrical fast transients test</b>	IEC61000-4-4 Level 3
<b>Surge test</b>	IEC61000-4-5 Level 3
<b>Conducted emission test</b>	EN55022, Class B
<b>Radiated emission test</b>	EN55022, Class B